

ERIC SIEGEL

EVS Electronic Video Synthesizer (Analog), 1970
Dual Colorizer (Analog), 1971

ONE OF THE MOST UNUSUAL personalities amongst the builders was Eric Siegel. Eric was flying on those undefinable wings of youthful divinity, propped up by willing muses. True, his art involvement was brief, and he soon lapsed into relative obscurity. A serious search found him again twenty years later.

From the child genius building electric boxes, to the socially engaged utopian reformer, from a self-educated dyslexic to an overland traveller from Europe to India, he had a keen sense of opportunity. In no time he initiated and organized a group with two of us called "The Perception". Howard Wise was the umbrella and it went on feeding other artists long after we departed to organize The Kitchen.

Our infatuation with Eric was probably conditioned by our coming from Europe. Europeans have always been perplexed by the unexplainable source of American talent: something springing up from nowhere without history, right in the belly of the beast of capitalism.

I always wonder why it took Eric to introduce this new image so convincingly. Something extraordinary happened when we saw that flaming face of Einstein at the end of the corridor. For us, something ominous, for me, something finally free of film. —W.V.

ONE OF THE EARLY adventurers into the realm of video, Eric Siegel was born in New York in 1944. He failed the electronics course in high school but went on to invent the PCS (Processing Chrominance Synthesizer) in 1968 which permits controlled colorizing of black and white videotapes and the EVS (Electronic Video Synthesizer) in 1970, by means of which abstract forms, mostly geometrical, can be created at will in color on a TV screen without the use of a camera. The "Einstine" tape, 1968, uses video feedback to produce it's psychedelic effects, and was one of the first video art tapes to use this technique. Siegel spent half a year in India, studying Hindu medicine and making videotapes.

A FEW WORDS *from an interview by Jud Yalkut.*

E.S.: For the last two years, out of necessity, I've been into a hardware trip, and in this time I've developed two pieces of video equipment, both of which were developed in San Francisco. I thought that I would work better out there. The main projects was the Electronic Video Synthesizer, that's like the video equivalent of a music synthesizer, where you have a program board and you can start to set up a whole series of visual geometric happenings in color on the video signals—the screen—and this is designed for video compositions. At the Kitchen last week (in 1973), I did a piece called Yantra Mantra with it, which was quite favorably received. The other piece of equipment is the colorizer. There have been, by the way, business and technical snags to getting out the EVS, but it is something that people should be able to go out and get. On the EVS, you just have to put in sync, and everything is composed right inside of the synthesizer. But you can put in live cameras too, and do things that involve pictures and synthesizer images.

So that's the EVS, and the other piece of equipment I've been developing parallel to this is the Color Synthesizer, or Video Colorizer, as people tend to



Frame 086 step through next 3 frames



STEP BACK



STEP FORWARD



Above: Eric Siegel, 1971, from a video tape made at the Howard Wise Gallery, New York City.
Right: EVS (Electronic Video Synthesizer), 1970

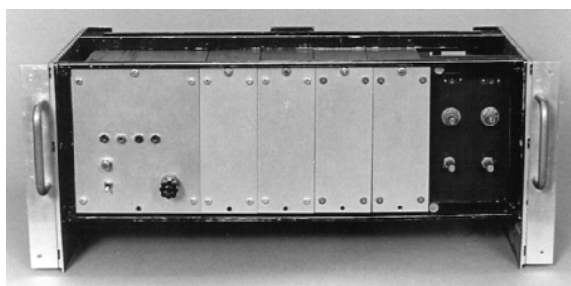
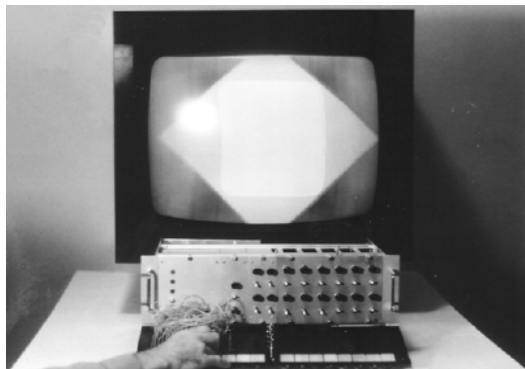

Dual Colorizer, 1972

want to call it. That takes black and white video signals, from 1/2" tape, like people who have been shooting with their portapaks, and it allows them to synthetically color the picture. This doesn't work out well for interviews or straight types of photography but it does work out extremely well when you move into the more visual and abstract things. And I found it also works out well with shots of natural mountains, sky, water, trees, nature, things like that colorize very well.

What do you think can be done to improve video as a healing technique? To improve the vibrational food that people get from it.

I think that depends wholly on the particular video artist who produced the video, they have to expand themselves, they have to go to the top of the mountain first, and then through their tapes show everyone else the top of the mountain. I haven't met too

many who have gotten to the top at all yet.

And also, as they say in Zen, when one goes to the top of the mountain, after achieving nothing, one must return to the marketplace. . . . Wasn't there, by the way, an earlier version of the colorizer?

There were a few earlier versions, as a matter of fact. I would put it another way: it has been under constant development and has gotten to a stage now where I am totally satisfied with the way it works. You see, all the previous ones that I made and that other people have made have many problem areas; you couldn't get the colors clean, within the areas and the borders; they would always bleed into the next things and smear and oscillate.

Some people did like that effect and still do.

Yes, there are some people who want this wild type of smeary effect, but I don't. I don't dig it at all, and

electronically, it is totally inaccurate, and I don't even agree with the aesthetics of it. So, the way mine is right now, the colors are very clean and totally within their borders and areas. At times it looks like chromakey, where you see two pictures cut in so neatly and cleanly that you're convinced that it is one picture.

Can we consider the synthesizer as a tool for the transmission of energy?

Karma energy, in the logic sense. I think the synthesizer will enable Western man to take advantage of the technology that he has created and only put it to the use of pro-life, pro-spiritual powers. I think that the synthesizer, used by people who have advanced to higher levels of consciousness, whatever you wish to call them, can be used in that way so that this can rub off to an extent onto the people at home watching it.

We mentioned earlier the possibility of having an interface between "electronic gurus" as we'll call them, who can speak through this transmission to each other, creating perhaps an energy field which is capable of enveloping a larger number of people.

Hopefully, yes. If this should continue, perhaps with the energy that is transmitted being received by other video gurus, so to speak, they would pick up on that and send a new flow of more concentrated energy back out into the airwaves once again, and start not an atomic chain reaction, but a psychic chain reaction.

A psychic chain reaction which in this case is being initiated totally by electronic means, by the direct electronic interpolation of the performer-guru in reaction to his external and internal environments.

E.S. Right. In other words, video, because there is this portable equipment, because it is being used to make this segment which will go out on the air now. Because there is this equipment, it means that you don't have to make videotapes in the environment that we're making them in now, and we're only isolated from the horror city by hundreds of feet

(Note: this interview was conducted in Central Park.) and so the karma of New York City is still upon us, and we can't escape that, and it will come through on this tape. But this recorder that we're using can be taken out where there is good karma to make recordings, and then the tapes can be sent to places like New York where there's bad karma, and good karma can be transmitted through the airwaves.

The synthesizer, too, is also basically a portable piece of equipment and can be used to broadcast quality transmission, or for 1/2," or for any type of equipment.

Yes, and as a matter of fact, it can be run on batteries. You can take a battery-powered tape recorder, a sync generator, and a video synthesizer, go up to the top of a mountain and do it. I think that technology is finally going to go into its second phase of existence—to help mankind, not for war.

The Electronic Video Synthesizer was created to enhance the interface between the Video artist and the people. Each human being is enshelled in his own perception of reality. Rational logical communications have their severe limitations. The communications which take place on the aesthetic abstract level deal with the inner tune of a being. It's like the DNA code of the artist speaking to the world. Since we all perceive different worlds, in the same worlds, it becomes our necessity to find witnesses, when we find the ultimate witness . . . we find love. The current trend towards religion and God is in a way a frustrated attempt to find the ultimate witness. One can not do without a witness. What you see on the screen is my attempt to get a witness deeper into your being. —Eric Siegel, 1973

Howard Wise was advancing a lot of money, he claims that it was a total of \$20,000 — I can only take him at his word— but my fingers never touched \$20,000. So there was this stress and strain of "c'mon, you've been funded, are there any results?" And at the end I felt that I'd been driven. I didn't feel good any more. But I did finish

Siegel Video Systems

S.V.S.

I wish to make it public knowledge that I have just developed the first all electronic video synthesizer in the world. It is called the Electronic Video Synthesizer (E.V.S.) and it makes pictures electronically. It is an instrument for the Creation of Color Visual information in the medium of video with the possibilities of at least one thousand different pattern variations. The unit can be performed on the air live.

It could also be used in a video tape session involving music for the creation of mythical trips. The colors are the most intense ever seen on any T.V. or monitor before. The E.V.S. does not have a B.L.D. (Brightness level distortion; problem.

***Note: BLD (Brightness level distortion) shows itself as incorrect brightness level on the video screen. Usually apparent in dark scans, showing up as a washed out grey.**

It is the instrument of the New Television; the growing tendency of more artistic abstract

television performed by beautiful enchanting people. Where conventional television seeks to inform and entertain the New Television will be engaged in expanding people's consciousness and providing a way for constructive meditation.

The E.V.S. hypnotizes you and the person playing it controls your trip. So the way you see the E.V.S. will depend on who is playing it. "It's the singer not the song."

This is the second instrument in the Siegel Video System. The first is the Video Chrominance Synthesizer which converts the gray scale of a monochrome video signal into a full color chrominance signal. A more detailed discription will be issued at a later time.

For inquiries, write to: Eric Siegel, c/o Howard Wise Gallery, 2 West 13th Street, Rm. 1011, New York, New York 10011, Tel: (212) 989-2316.

SOUND

A sound is composed of a basic frequency (cycles per second) A sound (or electromagnetic) source emanates from a point in a directional pattern characteristic of its frequency. The higher a frequency is the more directional it is. Cosmic rays, another form of electromagnetic energy, with a very high frequency, are highly directional. Sound waves are relatively low in directionality, however the effect of higher frequencies equaling higher directionality is still very apparent. Sound such as a yell or ticking of a clock are much more directional than the rumble of a trailer truck which is felt and has a larger sphere of physical stimulation. (Cosmic rays are attributed with the ability to change genetic structure)

Ideal Microphone—a piece of flat solid material which vibrates at the same frequency and intensity (a loud sound has more punch) as the sound source. This [plate] is connected to an electronic circuit where the variation in plate movements are transduced into a variation in the flow of electrons. This energy flow is measured in volts, amperes and db.

Good simple microphone techniques consists of getting as close to the sound you want recorded and making sure the mike is pointed at the sound source especially if the microphone has a directional (cardioid) sensitivity pattern.

RADICAL SOFTWARE

THESE TWO PIECES WERE OMITTED FROM ISSUE THREE.

it. Then I had to go back to NYC with the finished synthesizer and Howard Wise had some shows. I don't want to go into that because it was bad for me. I was placed in a show but it was not clear to me what was going on. So that was one of the exposures of the Video Synthesizer. It sat in one of Howard Wise's offices but what I had accomplished with it was elementary. It demonstrated to people that a video synthesizer was a viable piece of technology but I had not been to the point where I created an art work. I really wanted to create moving mandalas like you can see from India. The motivation for the synthesizer was to alter states of consciousness. I did a few things with it but I lost interest in the Video Synthesizer because it turned into a job."

Eric Siegel

January 21, 1992

San Diego, California

ERIC SIEGEL COLORIZER

The Eric Siegel Colorizer is a modulation based colorizer that generates color images from monochrome sources by adding a modulated subcarrier onto a black and white video signal. It is a derivative of a Video Processing Amplifier (Proc Amp) whose primary function is to cleanse the composite video of signal aberrations. The Proc Amp re-inserts the sync signal, adjusts the brightness, contrast (gain) and edge enhancement of the luminance component, while correcting the hue (phase) and saturation (amplitude) of the chrominance component. The Siegel colorizer modifies the functions of a Proc Amp by generating a synthetic subcarrier. It is then

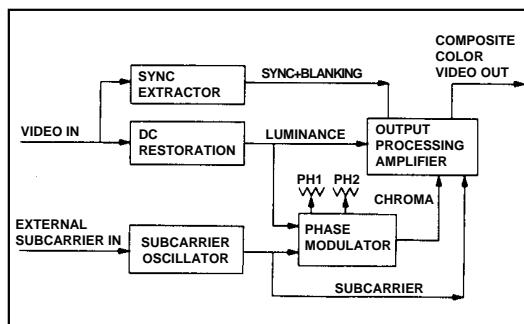

added to the luminance component of the input source which forms color from a black and white picture. The black to white excursions of the input signal shift the color hue. This generates multitudes of colors that track the brightness of the video.

A monochrome input signal is filtered of extraneous 3.58 MHz components then detail enhanced and run to a Chroma Phase Shift Modulator. The modulator links the video brightness to a phase shift of the synthetic color subcarrier, swinging it's output hue. The two stage phase shift circuit enables greater than 360 degree rotations in hue space, or "Ultra-Phase Modulation" of the chroma. The degree of phase shift and its polarity are selected through the front panel. The starting hue and saturation of the synthetic chroma, along with brightness and contrast of the output video, are adjusted through front panel controls.

ERIC SIEGEL EVS SYNTHESIZER

The EVS Video synthesizer contains many components of the Special Effects Generator (SEG), with the additions of a color encoder and free form patch matrix. Built in a BIC-VERO rack with front panel knobs and switches, a large horizontal plug matrix is present to patch together video effects. The patch panels were pulled from IBM style card sorters, with connections formed by mini-banana plug cables in a rainbow of adorable colors. In the front of the patch panels is a row of 16 white, flat rocker switches, arranged horizontally to resemble a piano keyboard. The matrix has 15 rows by 20 columns with various inputs and outputs scattered throughout the panel. The processing connections are carried back to the main rack unit. All voltages at the patch matrix are 1 Volt P-P, allowing for the connection of any output to any input. The outputs of the modules are low impedance and can drive multiple inputs. The synthesizer box has provisions for two video input sources, and a duplicate set of video outputs.

In the rack of electronics sits:

- 1) A power supply for the modules
- 2) Three voltage controlled *two-in-one-out* video mixers. These can switch at video rates, as well as mix the two video inputs depending on the control signal input.
- 3) A Horizontally and a Vertically locked sawtooth generator with a square and logarithmic waveform

output. These can be used to form horizontal or vertical patterns for use as a video or control source. The oscillators can be independently voltage controlled and “unlocked” to the horizontal or vertical timing source, causing the patterns to “wobble” horizontally or vertically.

4) A Horizontally and Vertically locked triangle/square waveform generator with logical combinations of the H and V patterns. This forms 4 basic patterns : a Horizontal bar, a Vertical bar, a square pattern formed from the “Anding” of the H and V bars, and a diamond pattern formed from the gating of the H and V triangle waveforms. All four outputs are available simultaneously at the patch panel. Size and position of the triangle/bars is controlled from knobs on the front panel.

5) Dual voltage controlled oscillator/generators with dual video attenuators. The voltage controlled oscillators can free-run or be locked to horizontal or vertical sync. The frequency of oscillation is selected through a rotary switch to switch the capacitive time constant. The video attenuators linearly attenuate from input to output, in response to the control input.

6) The output color encoder. The main color encoder of the Siegel colorizer is contained here. It is a conventional “doubly balanced modulator” to perform the hue and saturation generation from the control inputs. In place of a conventional R-Y and B-Y inputs, dual inputs are present on both modulators for inverting and non-inverting phase shifts. The first modulator axis is adjusted for orientation along the Red / Cyan axis, while the second modulator is set 90 degrees in quadrature on the Green / Magenta color axis. The modulator’s outputs are summed together and form the chrominance signal. The chroma along with the color burst is run to the output Proc Amp for combination, to form a composite color video signal.

The substitution of luminance video with and without waveform modulation helps to generate the unusual colorizing, with the hue and saturation changes determined by the horizontal components of the controlling waveforms. The overdriving of the

dual modulators with video signals has been described by Eric Siegel as “Ultra-Phase Modulation.”

7) The output of the colorizer goes to the Processing amplifier. The output Proc Amp merges and cleans up (blanks) the synthesized video to a form that is video compatible. It is here that the burst, sync and blanking is formed and gated, and the luminance and chrominance combined. Knobs are available to mix the Luma and Chroma proportions for the two main video output. — J.S.

