

# VIDEO

## YES, VIDEO!

ROBERSON CENTER FOR THE ARTS & SCIENCES  
in conjunction with the  
EXPERIMENTAL TELEVISION CENTER, LTD, of Binghamton, New York

offers a variety of programs in Video Art for

### 1.

YOUNG PEOPLE .....

Saturday afternoon workshops in which young people ages 8-12 can explore the uses of video by making, directing, and starring in their own television shows!

### 2.

JR-SR HIGH STUDENTS,  
TEACHERS, & ADMINISTRATORS.....

Workshops in video synthesis, black and white imagery, and digital video at your school or at the Experimental Television Center!

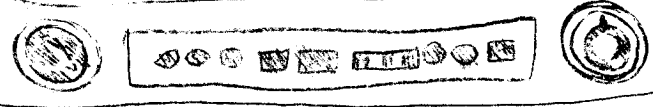
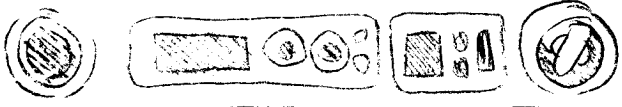

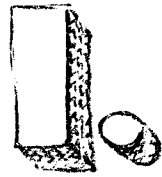

### VIDEO FOR YOUNG PEOPLE

In this 2-hour workshop, Brian Byrnes of the Experimental Television Workshop will show young people the fascinating uses of television, making images into stories, little stories into plays, and finally making, directing, and starring in their own television production.

**DATE: OCT 4, 1975 1-3 PM**  
**COST: \$5 per child**  
**RESERVATIONS REQUIRED**  
phone 772-0660 ext. 55  
(If enough interest is shown in this workshop, subsequent dates will be scheduled.)

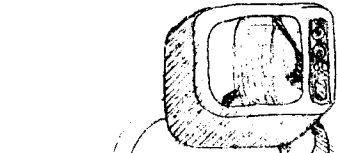

### VIDEO FOR JR-SR HIGH, TEACHERS, & ADMINISTRATORS

The following workshops are designed for Secondary students and their teachers and administrators. Sessions are organized to accomodate school schedules, and can also be held at the Television Center if necessary:



### VIDEO SYNTHESIS WORKSHOP

Conducted by Walter Wright, resident artist at ETC, this session includes lecture/demo of the techniques of color synthesis and image manipulation. Selected video tape illustrations will be used, 'hands-on' experience in small groups.

**GRADE LEVEL: 7-adult (30 max)**  
**AVAILABLE DATES: 1975-76 school year**  
**COST: \$85 per 1/2 day, plus mileage**  
(.15 per mile outside 25 miles of Roberson)

### DIGITAL VIDEO

A one-day workshop that introduces the concepts and circuits used in Modern Computers, showing how TV images may be generated and manipulated. Includes lecture/demo, 'hands-on' experience and small group discussions.

**GRADE LEVEL: 9-adult**  
**DATES: 1975-76 school year**  
**COST: \$165 per full day, plus mileage**



### BLACK & WHITE IMAGERY WORKSHOP

Conducted by Meryl Blackman and Peer Bode, this program introduces techniques of black and white image production and processing, using single and/or multiple camera systems and such techniques as keying, matting, and switching. 'Hands-on' experience in small groups, plus selected video illustrations.

**GRADE LEVEL: 7-adult (30 max)**  
**DATES: 1975-76 school year**  
**COST: \$85 per 1/2 day, plus mileage**

For further information and reservations contact the  
**EDUCATIONAL SERVICES DEPARTMENT**  
of Roberson Center for the Arts & Sciences  
30 Front Street, Binghamton, New York 13905  
607/772-0660 ext 50

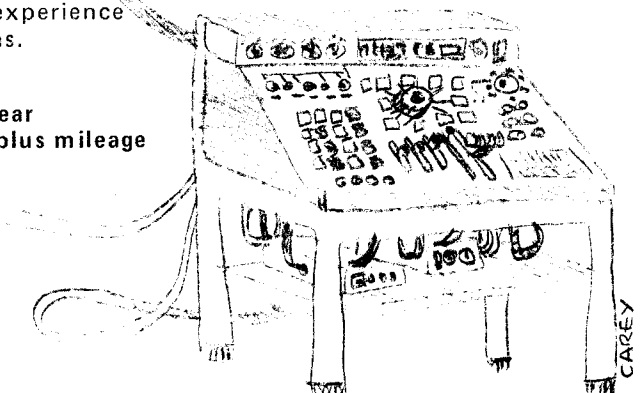
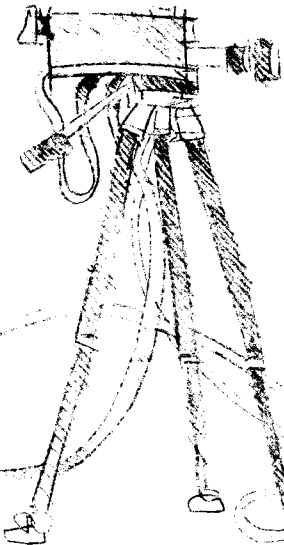
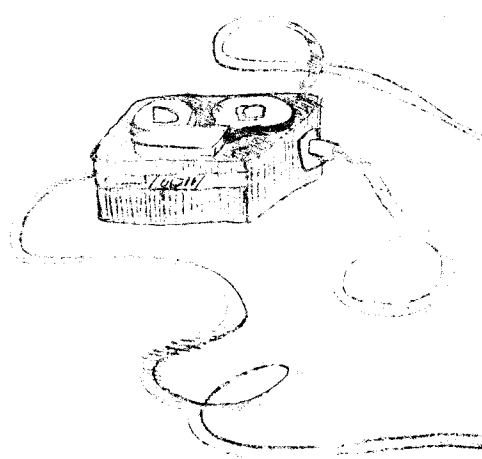

CAREY

## INFORMATION, WORKS AND ACTIVITIES

### Experimental Television Center

#### Permanent Systems

##### Untitled Activity – Peer Bode

Playback of picture and sound waveform images recorded of Everson's permanent collection.

##### Frames – Ralph Hocking

A series of frames from each of twelve videotapes made by Ralph Hocking and Sherry Miller from 1970-75 are presented photographically to allow perception of discrete image construction. Movement is reintroduced to each series through the presenting device.

##### Work For Round Screen – Ralph Hocking

A repetition of shape.

##### Jones Graphics – David Jones

This set of graphics presents a conceptual understanding of the functioning of the Jones colorizer. The systems approach reveals the parameters of this image making system.

##### McArthur Graphics – Don McArthur

A visual display of the computer-controlled video synthesizer system, its functions and processes. The lecture presentation of November 23 will explore the system in detail.

##### Video Drawing – collaboration

One perception of a video image; one representation of a video image.

##### Synthesizer

The Jones Video Synthesizer, developed for the Center by David Jones with support from the New York State Council on the Arts, is a four channel colorizer with keying capacity. It is an art making tool the capabilities of which include the mixing of up to four live or recorded camera images and the generation and mixing of electronic colors. The system is the basis for the workshops, performances and presentation to occur during the month and will also be installed in the Green Room with a color monitor matrix.

#### Temporary Systems

##### *November 5 - 11 Hourly*

##### Three Pillars – Meryl Blackman

Three pillars of monitors display black and white

videotapes emphasizing movement and spatial relationships. The position of the pillars with respect to the total spatial environment will be altered every three days to provide several different experiences of the tapes.

##### *November 5 - 14 Hourly*

##### Circle Cycle – Sherry Miller

An installation providing a variety of perspectives on a familiar activity.

##### Alfred Skerritt - A Portrait – Evangelos Dousmanis and Melanie Salzberg

A multi-media portrait of an early jazz musician and his music. Skerritt was very active in the development of jazz and Latin jazz in the United States from the early 1920's through the 1960's. He is now retired and living in New York City. Slides and photographs from the early jazz era are reproductions from Skerritt's original collection. There is also recorded music from that period including an unreleased Fats Waller tune. A videotape will be presented in the tape program.

##### *November 12 - 18 Hourly*

##### Meeting in Space – Meryl Blackman

A two channel work constructed from material from broadcast television coverage of the Apollo-Soyuz space shot. Two monitors display two tapes simultaneously creating additional meetings in space.

##### *November 16 - 21 Hourly*

##### Three Channel Piece Ft (O\* Δ) – Walter Wright

A preliminary study to identify the limits of the function Ft using three simultaneous channels of video. Channel one uses the image of a circle, channel two, a triangle and three, a triangle inscribed in a circle. Ft represents the various effects obtained using a sequencer and the possible interactions between channels. It is a study in fragmentation.

##### *November 23, 24 Hourly*

##### Sunsets – Jane Wright

Electronic sunsets on a monitor matrix.

##### *November 26 - 28*

##### Act Requiring Maintenance – Neil Zusman

An historical work requiring multiple viewpoints.

## WORKSHOPS, PERFORMANCES AND LECTURE

##### *November 6, 7 2:00p.m.*

##### Synthesis I – Peer Bode

Two one day workshops will provide an introduction to video synthesis systems. The format will include live video synthesizing, tape showings and discussion. The 'reality' of the electronic image will be explored as well as the notion of image as process/art as process.

*November 9 - 11 7:30 p.m.*

Synthesis II — Peer Bode

This workshop will allow for an extended involvement with video processes and includes three days of live synthesis, tape showings and discussions as well as an opportunity for individuals to do 'hands-on' work with the video synthesizer.

*November 16 - 18 7:30 p.m.*

Synthesis III — Walter Wright

Using the Jones colorizer this workshop concerns predicting the behavior of the system and the image, re-scan techniques, genlock techniques and the theory of electronic color.

These workshops are designed for people with an interest in the processes and concepts of video art and image making. The information and experiences are not intended to be sequential. Information presented in earlier workshops is not necessary for an understanding of later ones since each workshop approach differs. However, the workshops combined are quite comprehensive. Contact Richard Simmons at 474 - 6064.

*November 13 2:00 p.m.*

*November 20 2:00 and 8:00 p.m. Auditorium.*

Illuminations — Walter Wright

An improvisational performance work using an orchestrated flow of images presented on a matrix of color monitors. Representational camera images and synthesizer images are processed in real time with the Jones synthesizer.

*November 23 7:30 p.m.*

Computer-Controlled Synthesis — Don McArthur

A discussion of technical and aesthetic considerations in the design and use of a computer-controlled video system. The presentation includes slides and a videotape of images generated by such a system.

*November 5 - 28*

Videotape Program

This program is a collection of explorations and documentations made on videotape by numerous videomakers in conjunction with the Experimental Television Center. The tapes are shown either in total or as excerpted by Peer Bode and Sherry Miller, the tape organizers.

<u>Schedule A</u>	<i>Tuesdays and Fridays - begins at 12:00</i>
5.5 minutes	Window 1975 Meryl Blackman*/Peer Bode*
2.5	Boogie 2 1974 Meryl Blackman
11	Network 1974 Meryl Blackman
1	60 Second Lumination 1975 Peer Bode
6	Blue 1976 Peer Bode
15	Image Synthesis 1976 Peer Bode
5	1 - 87 1976 Peer Bode
10	Dolphin 1972 Walter Wright*
10	Paper Shoes 1972 Walter Wright
10	Titus Oaks† 1975 Walter Wright
5	Post Card 3† 1976 Walter Wright
81 minutes	

Schedule B *Wednesdays and Saturdays - begins at 12:00 (repeated)*

15 minutes	Inter-f'ace† 1976 Jean Pierre Boyer
2	Variations† 1973 Peter Diana
15	Breasts 1974 Evangelos Dousmanis/ Barbara Cieslicki
5	Painting Tapes 1975 Evangelos Dousmanis
6	Earth Pulse 1975 Gary Hill
5	Computer Generated Sequence† 1976 Don McArthur
5	Spatial and Intensity Digitization† 1976 Don McArthur
5	Two Lines 1976 Neil Murphy
9	Ducks and Geese 1976 Susan Rothstein
10	Spots 1976 Susan Rothstein
7	Metrovision 1975 Jim Tusty
5	Fan† 1974 Art Weingarten
3	First Portrait Drawing 1974 Arnold Zane/ Dena Crane
20	Studies For An Angel and Other Flying Figures 1976 Neil Zusman
	<i>(KidsTapes)</i>
2	West Side Junior High Kids† 1975 Louise Hammond, Francey, Kelly, Marcia and Sherry
2	The George Jumper Show† 1973 George Jumper
4	Utica Kids† 1974 Brad Lemery and Kids
4	Summer Tapes† 1976 Dana and Janet Marsh
124 minutes	

Schedule C *Thursdays and Sundays - begins at 12:00 (repeated)*

5 minutes	Could Be Dance (American Dance Asylum)† 1975 Brian Byrnes and Bill Jones
10	Ideal Canoe† 1973 Ken Dominick
15	Vasulka Workshop† 1971 Ken Dominick
15	Alfred Skerritt 1976 Evangelos Dousmanis
10	Bedford Stuyvesant Kids† 1970 Angel Nunez
12	TV Bed† 1972 Ralph Hocking/ Sherry Miller/ Charlotte Moorman/ Nam June Paik
15	Making of Selling of New York† 1972 Ken Dominick
7	Selling of New York 1972 Nam June Paik
89 minutes	

† excerpted videotapes

\* artist in residence

# VIDEO\* by VIDEOMAKERS 1979

\*L., VIDĒRE, TO SEE

## 5 EVENING EXHIBITIONS OF PROCESS VIDEO IMAGING WITH THE ARTIST PRESENT

Programs begin at 8:00 p.m.  
Open to the public without charge

MARCH 29	RALPH HOCKING	"SELECTIONS 1975-78"
APRIL 5	GARY HILL	"SUMS AND DIFFERENCES" "WINDOWS" "ELEMENTS" AND OTHER RECENT TAPES
APRIL 19	SHIGEKO KUBOTA	"VIDEO SCULPTURE" "DUCHAMP PIANO"
APRIL 26	ERNEST GUSELLA	"EYE AND EAR OPERATIONS" "NO COMMERCIAL POTENTIAL"
MAY 3	WOODY VASULKA	RECENT VIDEO OF ANALOG AND DIGITAL EXPRESSIONS

The EXPERIMENTAL TELEVISION CENTER is a video facility dedicated to the production and study of electronic imaging.

The Center's programs include a production facility of image processing and synthesis devices available to independent videomakers, a video tape and print library, a series of workshops and exhibitions as well as a program of research and development of video tools and systems.

The E.T.C. is supported in part by the N.Y.S.C.A. and N.E.A. with assistance provided by the Department of Cinema, S.U.N.Y., Binghamton.

Experimental  
Television  
Center

164 COURT STREET  
BINGHAMTON, NY 13901  
(607) 723-9509

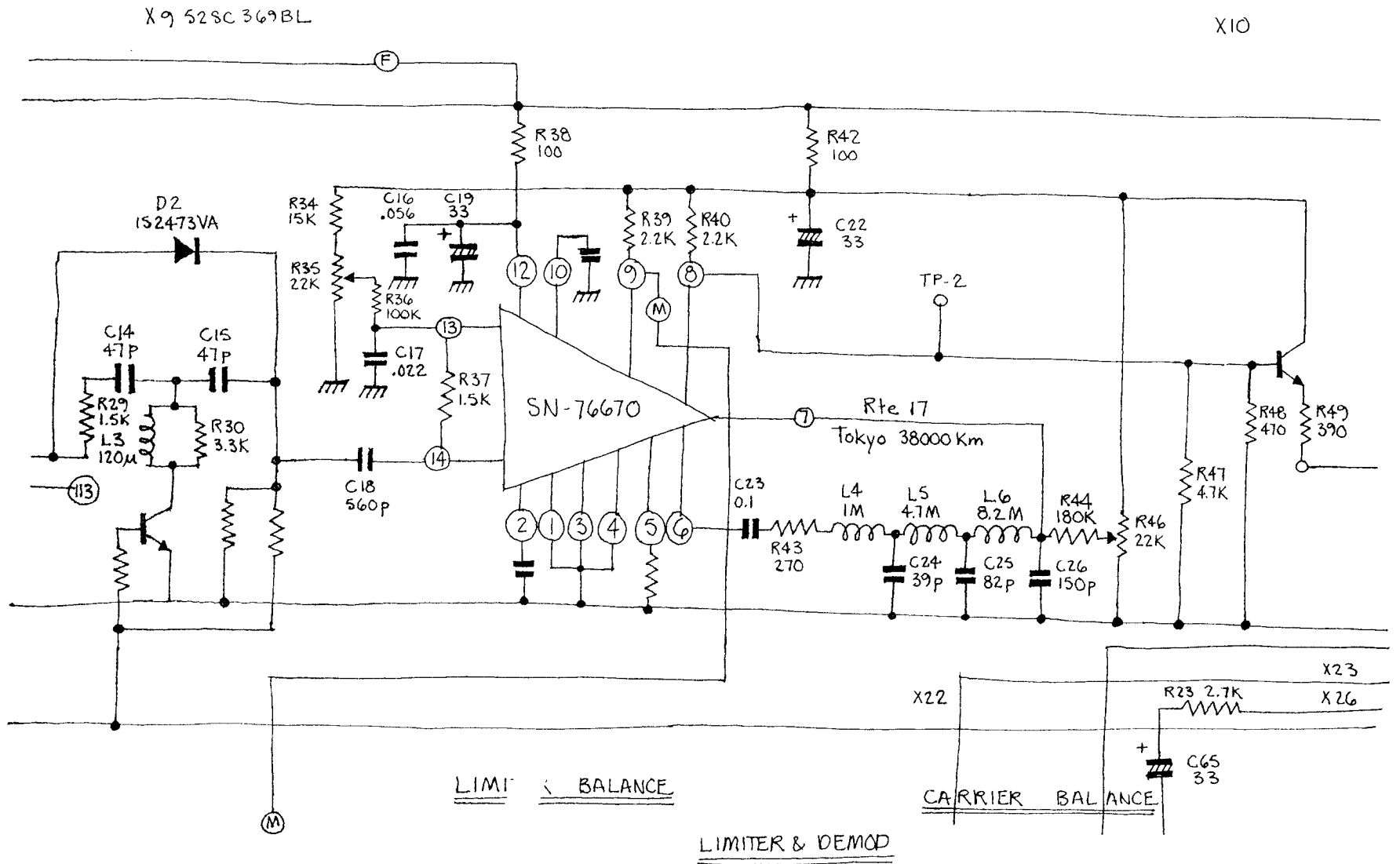

**Fri. February 21, 1975 8:30 pm**  
**Sat. February 22, 1975 8:30 pm**

at the  
**EXPERIMENTAL TELEVISION CENTER LTD**  
**164 Court Street**

**ETC in conjunction with the American**  
**Dance Asylum**

David Jones  
 Sherry Miller  
 Susan Wolfson  
 Walter Wright

Meryl Blackman  
 Peer Bode  
 Brian Byrnes  
 Ralph Hocking

Jill Becker  
 William Jones  
 Lois Welk  
 A. M. Zane

ADMISSION FREE

E.T.C. IS SUPPORTED IN PART BY THE  
 NEW YORK STATE COUNCIL ON THE ARTS.

THE AMERICAN DANCE ASYLUM AND THE EXPERIMENTAL TELEVISION CENTER LTD.

VIDEO AND DANCING IN BINGHAMTON

17 Minute Dance	Lois Welk, Jill Becker, BT Jones, Arnie, Meryl Blackman, Peer Bode
TV	Peer Bode, Meryl Blackman, Cara Brownell, Bob Waren
Portrait	Meryl Blackman Friday Lois and Jill Saturday Jill and Cara
Synthesizers The audience is invited to walk around the space during this section.	Walter wright, Susan wolfson, Ralph Hocking, Sharry Miller
Conga	Julius (Ebok) williams, Jr.
Couldbe Dance	BT Jones, Brian Byrnes, David Jones
Matrix Dance	Peer Bode Lois Welk, Meryl Blackman, Jill Becker, Cara Brownell, Hillel Oolgenas, Robert Hoover, BT Jones, Bob Waren, AM Zane, Neil Zeisman

Susan Wolfson, walter Wright and David Jones will perform on the Synthesizers at the conclusion of the program.

Special thanks to: Pat Halligan, Barbara Krasnoff, WHUT and SUNY-Binghamton for the loan of equipment.

The Experimental Television Center is supported in part by grants from the New York State Council on the Arts.