



# BILL HEARN

**VIDIUM (Analog XYZ driver/sequencer), 1969**

**ONE FOGGY SUMMER day in San Francisco, near Golden Gate Park, we saw a most peculiar building. We walked in without anybody noticing until we came to a halt in front of the most beautiful electronic picture-making instrument we had ever seen. "You are in the Exploratorium and I am Bill Hearn", said the man leaning over the instrument.**

**We were to later meet Bill many times and he was to become one of the most prolific instrument builders in video. He was in full concentration over the "Vidium". I have no other recollection of our conversation and apparently neither does he..**

**From Skip Sweeney we learned that he also built a colorizer which they had at Video Free America. We were invited to come over and play. We were very impressed by the way VFA had built an alternate institution and quickly pronounced Skip the Unequivocal Master Of Video Feedback, a title not contested to this date..**

**Hearn's career continues to this day. Many video artists have made masterpieces on Hearn's Lab, notably Ernie Gusella and in this world of quick obsolescence, Steina is still using two of his old instruments.**

**—W.V.**

**CURRENTLY** William Hearn is a Staff Scientist Engineer in the Electronics Engineering Department at the Lawrence Berkeley Laboratory, University of California. Educated in engineering at Berkeley, he has been employed since 1973 in the Accelerator and Fusion Research Division at LBL, where he was instrumental in the development of the EBIT (Electron Beam Ion Trap), the Tandem, the Magnetic Fusion Experiment, Real Time Systems, and the Heavy Ion Linear Accelerator. He has several patents issued in his name.



INFO Frame 14926 to 18820

**"I WAS A CURATOR** at the Exploratorium and I had designed a really large console that made complex color lissajous patterns: multiple locked oscillators and pseudo-three dimensional shapes. I always thought they were quite beautiful. They had been used in a couple of different applications but I made a large console that would generate great families of them.

I got the idea from somebody else in New York who had done it long before me. I saw what he had done. I improved the deflection amplifiers to give a really good response and I developed a system of color modulation which I have a patent on. It painted color on the surface according to the convolution of the surface.

The monochromatic versions were beautiful, very lacy and sharp. They had a very sharp trace on the electromagnetic CRT. And if you can deflect the beam, which is very difficult, you can get beautiful patterns from voice or recorded music.

For color the basic trick is that the color is a function of the velocity of the trace as it moves on the screen. As the trace moves, the color stretches toward the red end of the spectrum. You know what the spectrum looks like. It starts at red and goes through orange, yellow, green, blue and then violet. I assigned colors according to the actual velocity of





Bill Hearn in the mid-60s

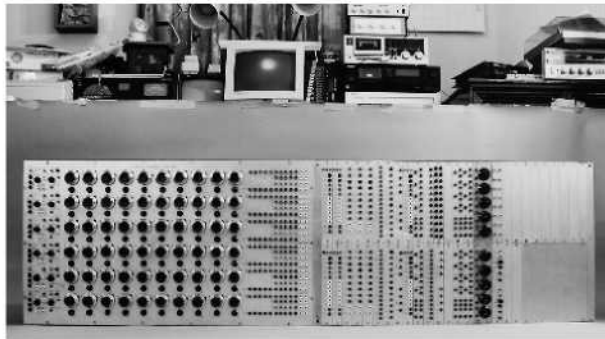

VIDIUM

the trace on the screen. I had circuits which could measure the velocity and change the color of the dot as it was moving. In doing that it made the contours of the image stand out in a really interesting way.

It's been many years since I've done a thing on it because it was such a dead end. I found that it was quite interesting and beautiful but it had no commercial application. People in special effects, film or advertising all have very tried and true techniques that they stick to. They don't want anybody coming in and disturbing their nice game.

I paid for all of it myself up to the point where I got some exposure, and a very wonderful man named Al Leavitt here in San Francisco, who later turned out to be a kind of pain in the ass, saw it. He loved it and he said we should exploit this. I said fine and he made a contract with me through negotiations with my attorney. We formed the Color Communications Corporation. Al put in \$30,000 and I put in my patent and then he died. I never would have been able to do what I did if Al had lived. That's the funny part of it. He died of a heart attack at the beginning of the project and the money was in the bank and I went ahead and built this thing.

Through EAT I met a number of budding electronic music composers. I helped them build music synthesizers and when I developed the Vidium, they

found that it was a really sympathetic way of producing images directly from their signals to get a visual synthesis of what they were doing sonically. Don Buchla came by for a few meetings and I think David Tudor was very interested in it.

Don Buchla was the strongest influence I ever had in terms of the way he did things. If you look at this you'll see that it's very similar to his synthesizers in the philosophy of what it does: control voltages, logic voltages, signal voltages and unshielded banana jacks, so that you can stack them which makes the flow much simpler. I think technically you can say that this machine could have been designed by Don Buchla.

The people at Video Free America in Berkeley asked me to make a colorizer for them: Arthur Ginsberg, Skip Sweeney and Alan Shulman. They showed me that they had a colorizer but when they opened it up all the parts fell out. It was a little thing in a gray box about this big and it cost \$800. It had two knobs on it and made a smeary color. I said, "we can do better than that." At that point I evolved the concept of the zone colorizer to cut the gray scale into segments.

What I really lust after is to make machines that are so clear to a creative person and gives them so many possibilities that they can use them. It just gives me a terrific thrill when I see someone like Ernie Gusella in New York who's doing truly creative work with the Videolab." —B.H.

**THE VIDIUUM "MK II"** is a hybrid analog synthesizer which acts as a "hyper Lissajous pattern generator." Developed by Bill Hearn in the early 1970's, the Vidium was inspired by earlier color XY display art and an exhibit called "Sidebands" at the Exploratorium in San Francisco. The fascination with animated color shapes driven from sound formed the basis for Vidium. Numerous XY displays and audio function generators were tried before arriving at the current form of the MK II unit.

The basic Lissajous pattern is generated through two waveforms attached to an X/Y display screen (or oscilloscope set in XY mode) with two sine waves driving the horizontal and vertical deflection circuits. With the X axis sinewave "in-phase" and the Y axis "out-of-phase" a shape is seen on the display. If the phase shift is 90 degrees, a circle is formed, with 45 degrees an ellipse is seen, and with 0 degrees of shift a diagonal line is seen.

The Vidium drives each axis with independent oscillators while inserting precise phase shifts and modulation signals to create elaborate shapes. These are expansions on the classic circle and figure eight pattern appearing as "harmonically pinched doughnuts" and vector textures of slowly changing form. Programmable waveforms of sinewaves shift into triangle waves, and then into square waves to deflect the XY display beam, forming sinuous curves and boundaries.

A modified color television is used for the X,Y display with the deflection yoke replaced with a new yoke driven from audio amplifiers. The audio amp is in turn driven from the main analog waveform generator rack. Color is added by wiring to the color "hue control", forming a voltage controlled phase shifter, and wrapping, in phase, 540 degrees of the normal 360 degree hue space. Color saturation and brightness is set by the TV's front panel controls. A special analog velocity/position detector calculates: the square root ( $X^2 + Y^2$ ) of the deflection signals that feed the color hue shifter. A threshold detector blanks the beam if the X and Y settles to zero. This suppresses the beam of a stationary dot at the center of the display, which can "burn out" the screen phosphor. The hue shifter allows drawing of textural surfaces in smoothly changing colors. The hue shift tracks the shapes automatically.

The main control box consists of two, 3 foot by 3 foot, racks mounted side by side. The left side

contains the "voltage sequencer" outputs with 60 multi-turn knobs called Helipot, while the right side of the control rack contains the control and signal processing modules.

The main control of the synthesizer is an Analog Voltage Sequencer. The "sequenced voltage source" has six controllable "steps", each "gating ON" 10 voltages; the voltages set by ten-turn potentiometers located on the left half of the rack. This six by ten matrix of voltages is interconnected through "Pomona Stacking Banana Plug cords" to other modules located on the right half of the rack. Commonly the sequencer is wired in a tandem chain of modules: the first module triggers the second module etc., until the sixth sequencer step is triggered. An oscillator or button at the front end starts up the chain of events. Each "step" has a time delay (a monostable multivibrator), and a light bulb to indicate that it has been triggered. Output jacks for OSC START, SEQ OUT and EOS (end of sequence) are used to connect to the next module in the sequencer chain.

Control voltages are available on colored banana jacks with RED representing analog outputs, BLUE for analog inputs, BLACK for digital inputs and WHITE for digital outputs. The digital output signals have a "Wired-Or" property to tie multiple outputs together with the lower voltage being the victor. The Analog Voltage Sequencer can have its outputs tied together due to its "bare-collector" output stage. This allows the sequencer to "switch-on" up to ten voltages for each step in a sequence.

The pattern generator side is built around basic sinewaves and phase shifted sinewaves. The modules consist of oscillator frequency sources and processing modules. Multiple oscillators are present, including a voltage controlled function generator. This allows for voltage control of it's frequency and phase, and an external sync input. The output generates a collection of waveforms: triangle, square, sawtooth and sine. A digital version of the "trigger out" and a waveform triggered indicator, "logic out", are made available on separate jacks. A more elaborate version was proposed to allow voltage control of waveform shape; the input voltage would shift the output waveform from sine through triangle to square.

Another signal source is an envelope generator. A trigger pulse, "ENV START", starts a pulse output, and "ENV STOP" turns off the pulse. The rise/fall

time of this pulse is voltage controlled and digital outputs indicate that the envelope has triggered. The envelope pulse is combined with the main oscillators to smoothly shape the underlying waveform.

Closely tied to the idea of Lissajous pattern generation is the need for controlled phase shift of the sine wave signal. To accommodate this, a modified "All-Pass" filter circuit is available where the input signal is phase-shifted in response to an external voltage control.

For processing of waveforms, a Voltage Controlled DC coupled Amplifier is present, acting as a two quadrant multiplier with a summing input stage. The amplifier sums together multiple inputs while the voltage control input attenuates the summed result and sends it to output. The control signal can come from the envelope generator, the sequencer voltage or the oscillator waveform: Output =  $(In_1 + In_2) \times Control$ .

A precision Four quadrant multiplier with two sets of inputs, A and B with inverting and non-inverting polarities is used to modulate the oscillator waveforms: Output =  $(In_{A1} - In_{A2}) \times (In_{B1} - In_{B2})$ . These four quadrants allow both attenuation and inversion of input waveforms.

The combination of the Voltage controlled summing AMPs, with Four Quadrant multipliers and

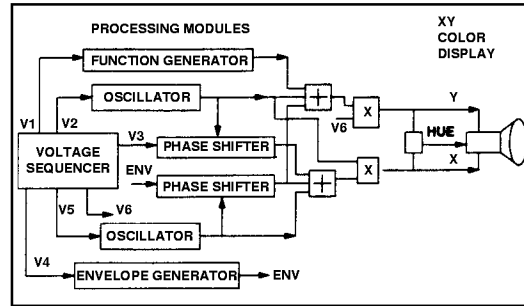

phase shifters, allow the multiple oscillators, envelopes and knob control voltages to mingle their signals into curious patterns of X and Y signals. The hue shifts are closely linked to the pattern drawn by the X and Y waveforms, forming the unique interlocked VIDIUM Lissajous surfaces.

The front panel was constructed by Joshua Partridge and the circuit boards were assembled and tested by Richard Rhoda. Bill Hearn designed the detailed circuits and originated the concept for VIDIUM. He holds a U.S. patent based upon the color display subsystem titled "Visual Display of Complex Color Television Soundwave Signals", number 3,627,912, granted on December 14, 1971.

—J.S.